



//INTRODUCTION

When the weather is up for it, I love to cook outside. With this outdoor kitchen, I can do my chopping, peeling and cooking outside.

The outdoor kitchen comprises of gas cooking hob, a bucket sink, a chopping board and storage for crockery, utensils and a few food ingredients. Water is connected from the garden hose and waste water is collected in a watering can placed beneath the sink, so grey water can be reused. The product instructions give different options for construction depending on level of skill and access to tools. However you need to be confident in the workshop to embark on the making of this, alternatively you could get a skilled carpenter to make it for you. All the components are sourced from hardware stores. The boxes are constructed from one sheet of ply and the structure with broomsticks and some screws. Surface treatment can be made tailored to suit personal preference and taste, the version shown is treated with Osmo oil.

//MATERIALS REQUIRED

castor (metal rim heavy duty) 125mm
8.5m length of broom handles 28mm dia. meters
gate valve (compression fitting) 15x15
22mm x 1mtr copper pipe
solder ring/fitting reducer 22-15mm
Washer m6 x 25
Washer m6 x 20
cross dowel m6
cross dowel bolts m6 x 80mm
hinges
hose connector
plastic bowl
watering can
Foker Cast iron single gas burner .
Gas flask
2440*1220 6mm ply wood
5m length of 20mm x 20mm batton
Osmo finishing oil
angled sink waste 1.25"

//TOOLS REQUIRED

table saw
router
saw
drill
4mm drill bit
countersink drill bit
28mm forstener drill bit
pinkgrip d4 wood glue
sandpaper
selotape
clamps
vice
tape measure
pencil for marking up
centre punch
chalk
micrometer

01. source all materials required to construct the whole project.
02. decide what type of corners you would like to make the boxes for this project with. there are three options shown on the following pages.
03. mark up and cut out from the plywood sheet all the elements required to make the boxes. this is shown for the mitred corner option.
04. cut all holes and openings in parts for boxes (excluding those for plumbing).
05. glue and clamp boxes until dry. certain joints will need to be selotaped in order that they do not get stuck.
06. cut all broomsticks to length.
07. drill all connections in broomsticks.
08. assemble boxes around broomsticks.
09. tighten up broomstick connections.
10. complete boxes.
11. fix drawer.
12. fix plumbing.
13. make chopping board.
14. attach wheels.
15. wait for a summers day.

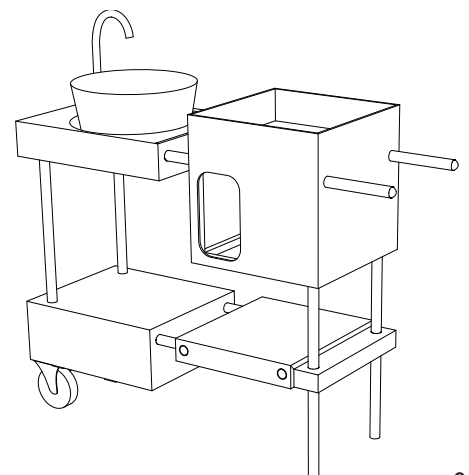

//UNDERSTANDING THE NOMENCLATURE//

//for convenience the outdoor kitchen has been split up into five elements these being the four boxes and the frame around which the boxes are built.
the colour coded drawing below sets out the names and part numbers for all the elements

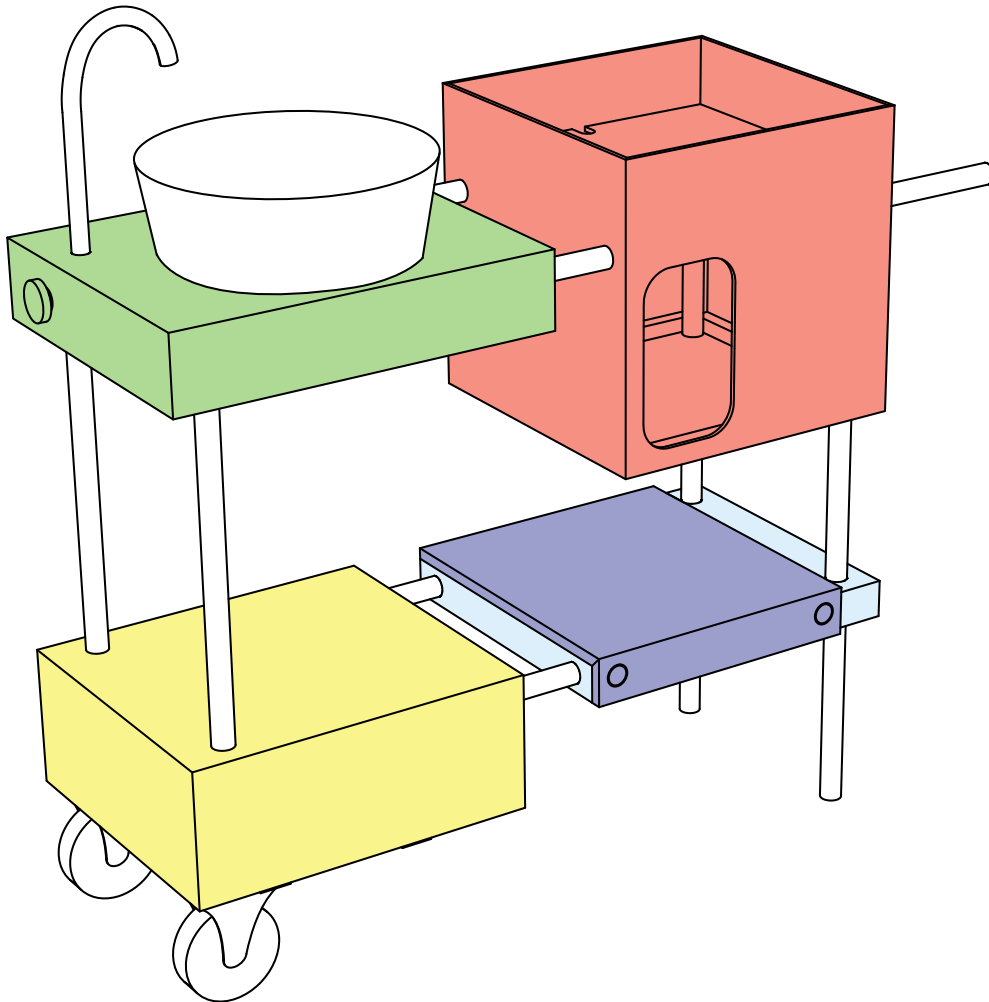

sink box	(SB01-09)
burner box	(BB01-08)
drawer box	(DB01-09)
chopping board box	(CB01-06)
chopping board	(CB07-09)

02 there are a number of ways of constructing the corners of boxes, some are simpler and require less skill and equipment others which require a high degree of experience and equipment.
the instructions below are for the mitred corner box. this gives a very clean corner to the box.

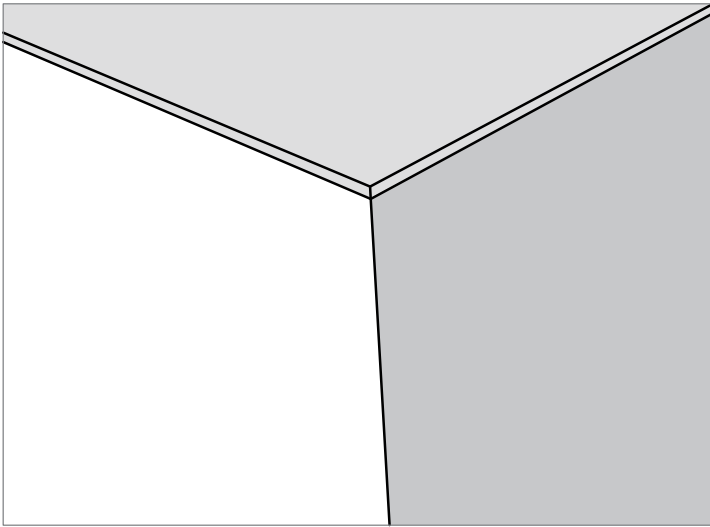

mitred corner

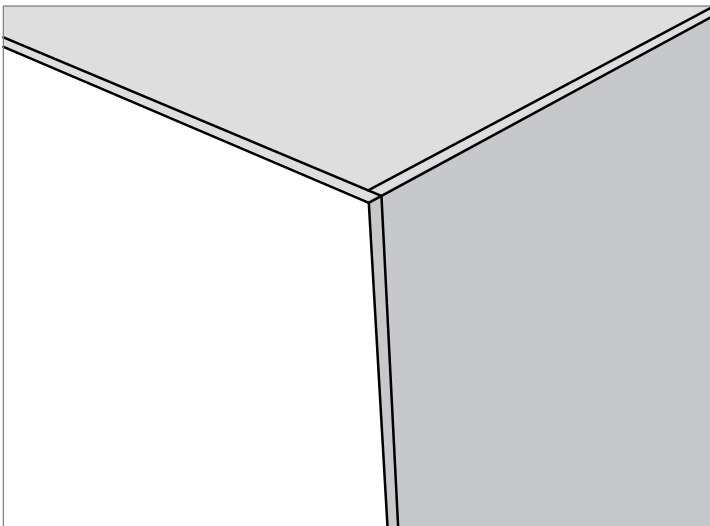

butt jointed corner

03 start by chalking out on the sheet of plywood the pieces as shown on the next page. using chalk allows for mistakes to be easily changed. it is worth chalking onto the individual pieces both their designation and their dimensions this allows for ease of identification and checking later on the construction process

using a bench saw or workbench mounted router, mitre the sides of the boxes as indicated above. both these pieces of equipment are potentially dangerous and care should be taken. if you feel uncomfortable using such equipment please seek the help of a professional or someone more experienced. alternatively see above as to simpler alternatives as to how the corners of the boxes can be made.

before drilling the holes for the broomstick frame using a micrometer measure the diameter of the broomsticks. broomsticks are not manufactured to a high specification and so a variety of diameters may be found. the dimensions used throughout are for 28mm broomsticks. these should be adjusted accordingly. measuring the broomsticks will allow you to purchase the correct drill bit to cut tight fitting holes for the brooms to pass through.

// PLY SHEET CUTTING LIST //

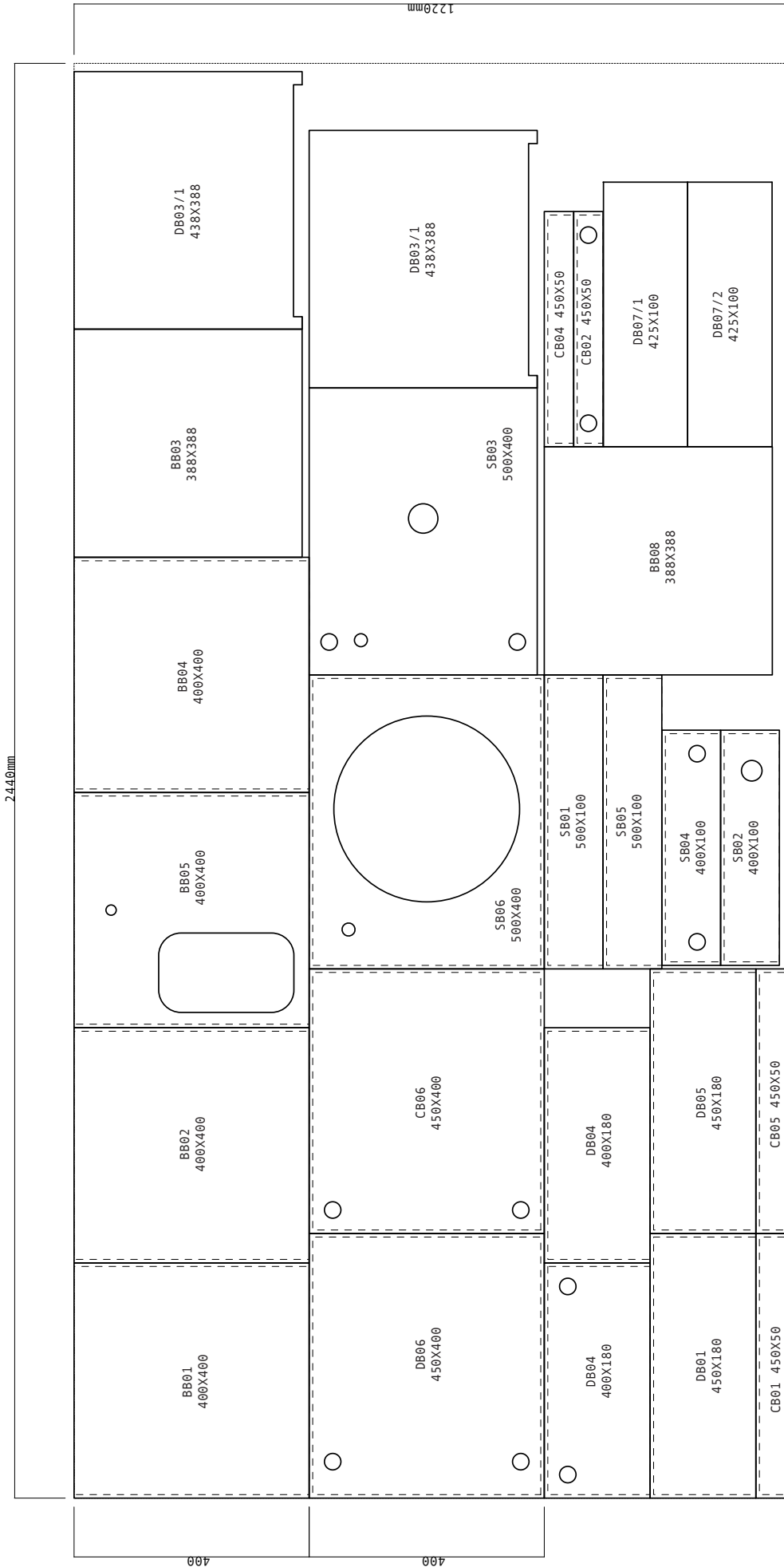

— Cutting line
 - - - Mitre line
 Sheet outline

// BURNER BOX CUTTING LIST //

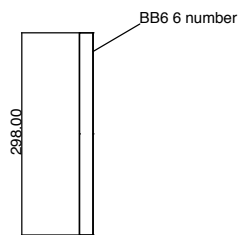
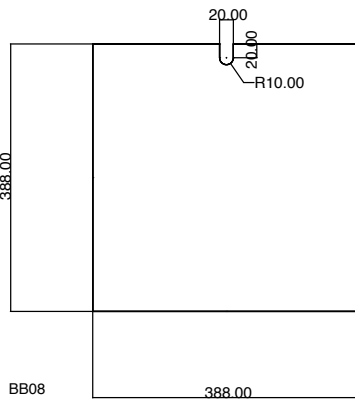
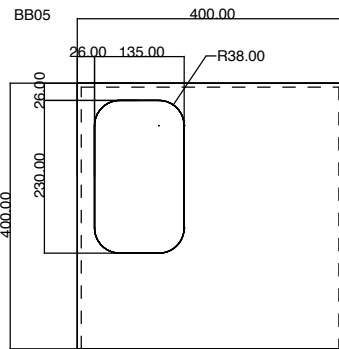
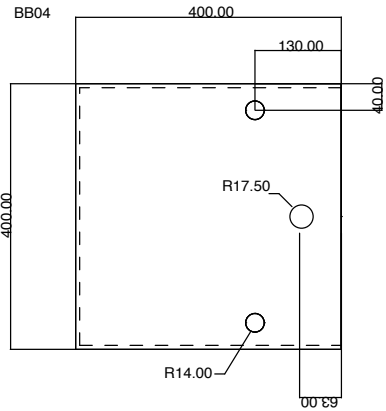
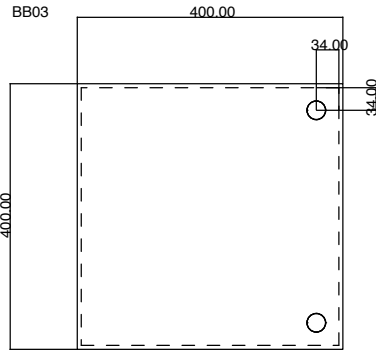
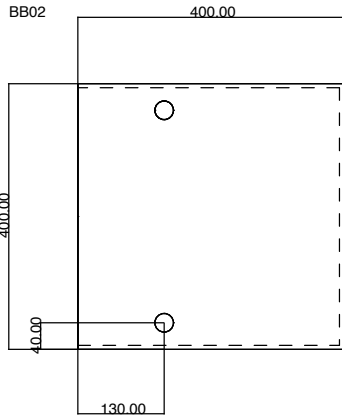
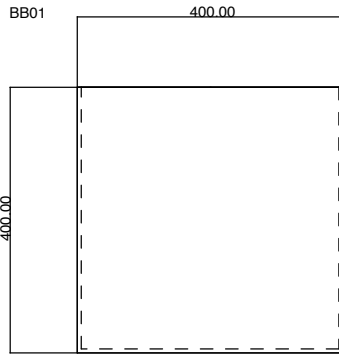

BB06 and BB07 to be made from 20mm by 20mm timber



All panels to be made from 6mm Ply
 Sides BB1, BB2, BB4 and BB5 to be mitred on both sides and bottom
 Side BB3 to be mitred on all sides

// SINK BOX CUTTING LIST //

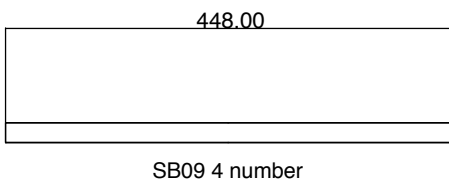
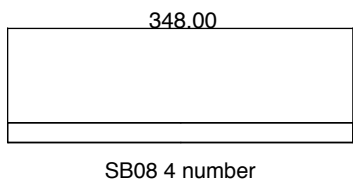
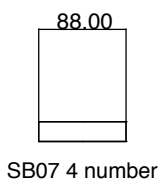
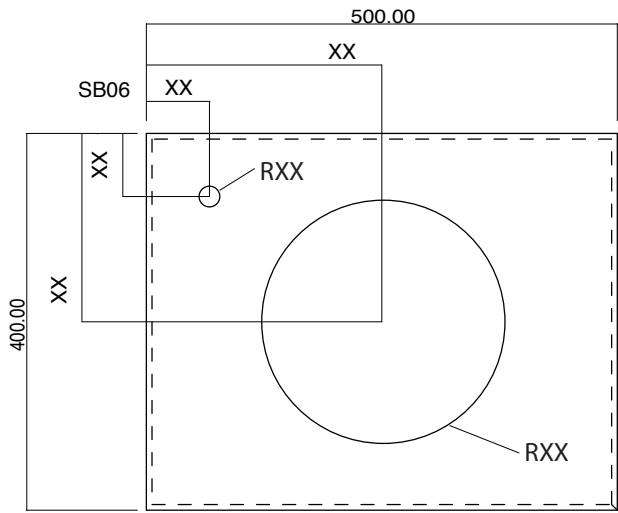
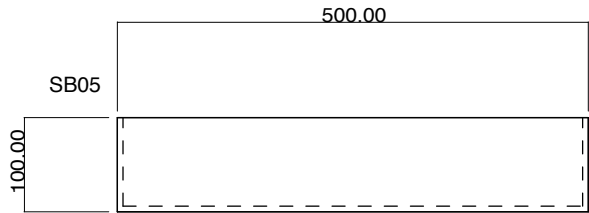
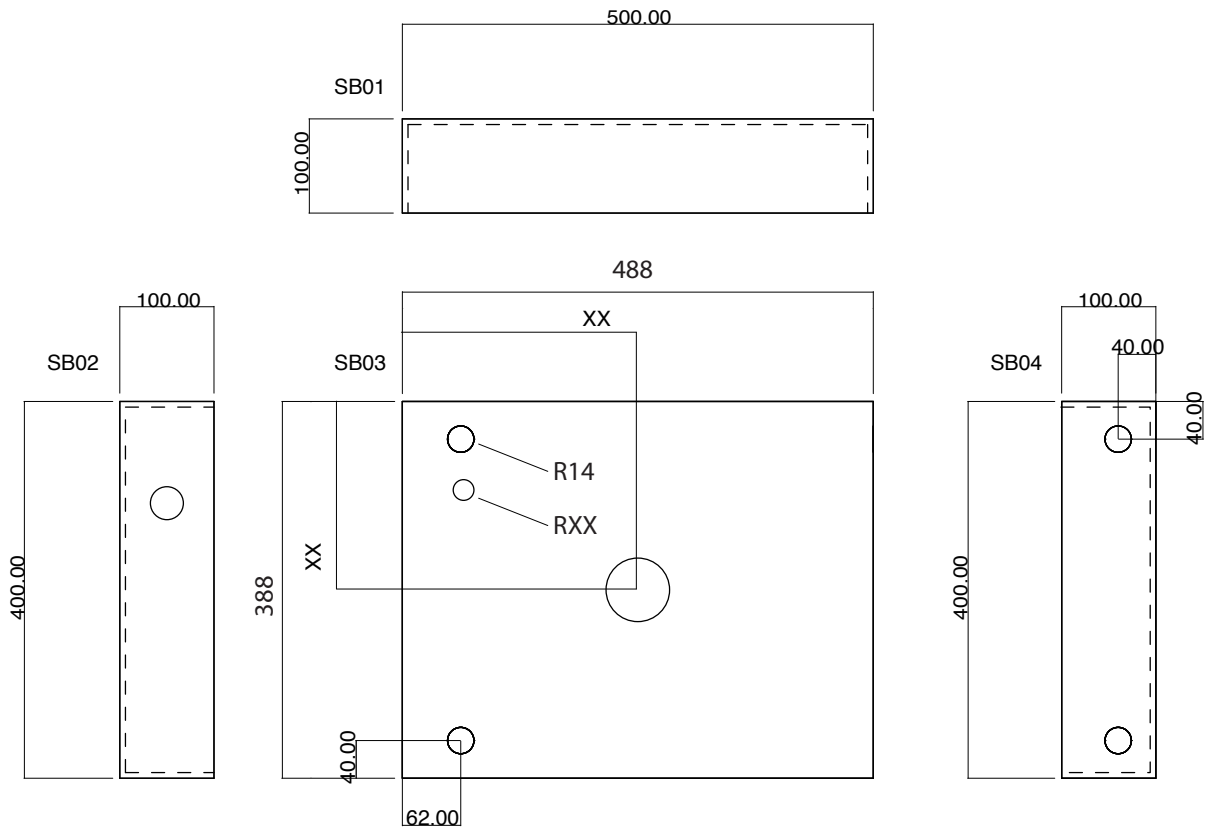

SB07-SB09 to be made from 20mm by 20mm timber

// DRAWER BOX CUTTING LIST //

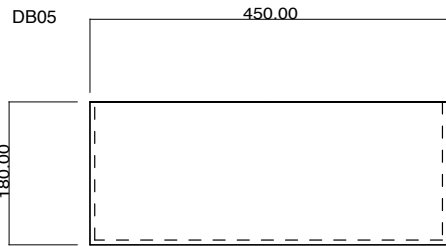
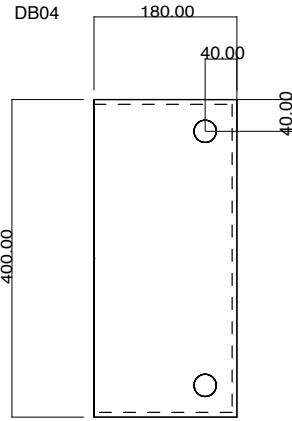
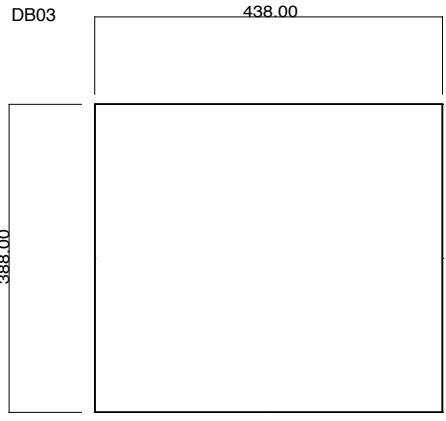
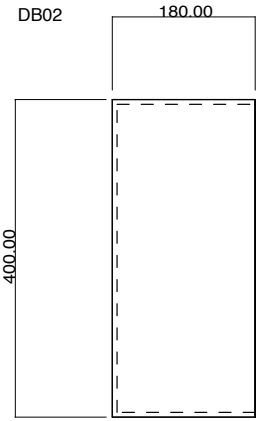
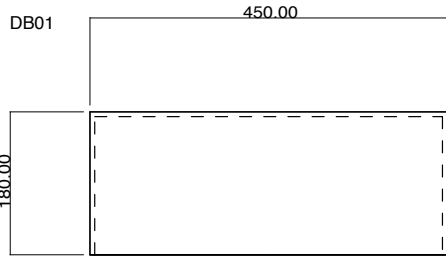

DB01, DB02, DB04, DB05 and DB06 to be made from 6mm Plywood
 DB03 to be made from 12mm Plywood
 DB01, DB02, DB04 and DB05 to be mitred on top and sides
 DB06 to be mitred on all sides

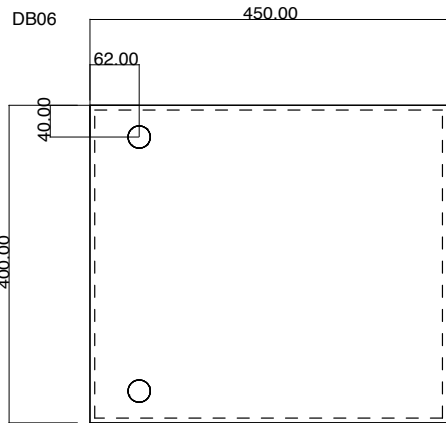

DB07 2 number

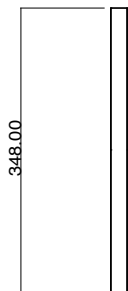

DB08 3 number

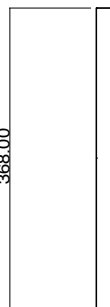

DB09 4 number

DB07 - DB09 to be made from 20mm by 20mm timber

// CHOPPING BOARD BOX CUTTING LIST //

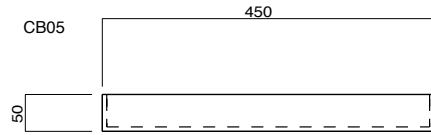
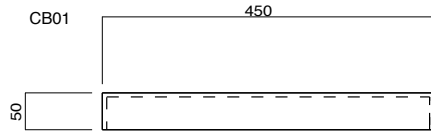

CB01 - CB06 to be made of 6mm Plywood
 CB01 - CB06 to be mitred on all sides

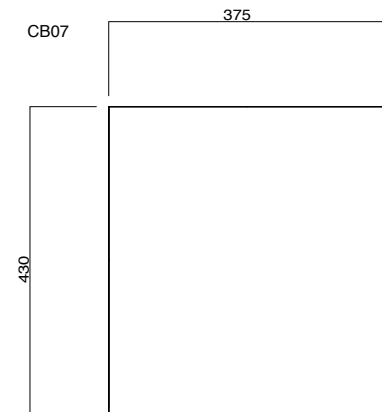
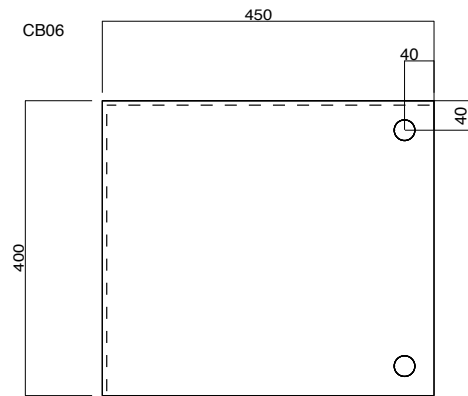

CB07 - CB09 to be made from 15mm thick timber

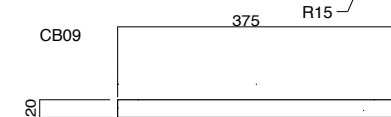
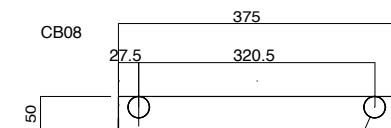

// FRAME CUTTING LIST //

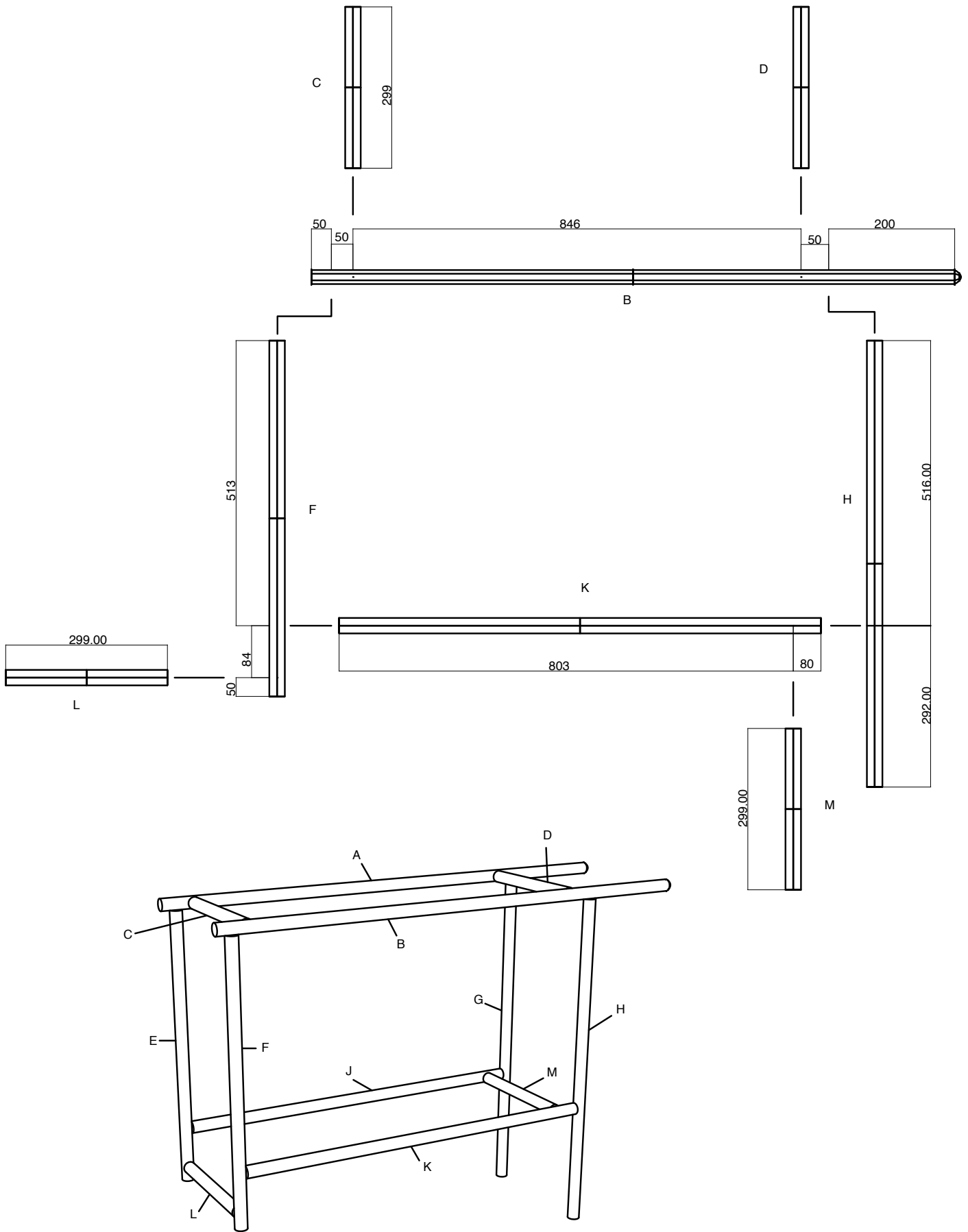

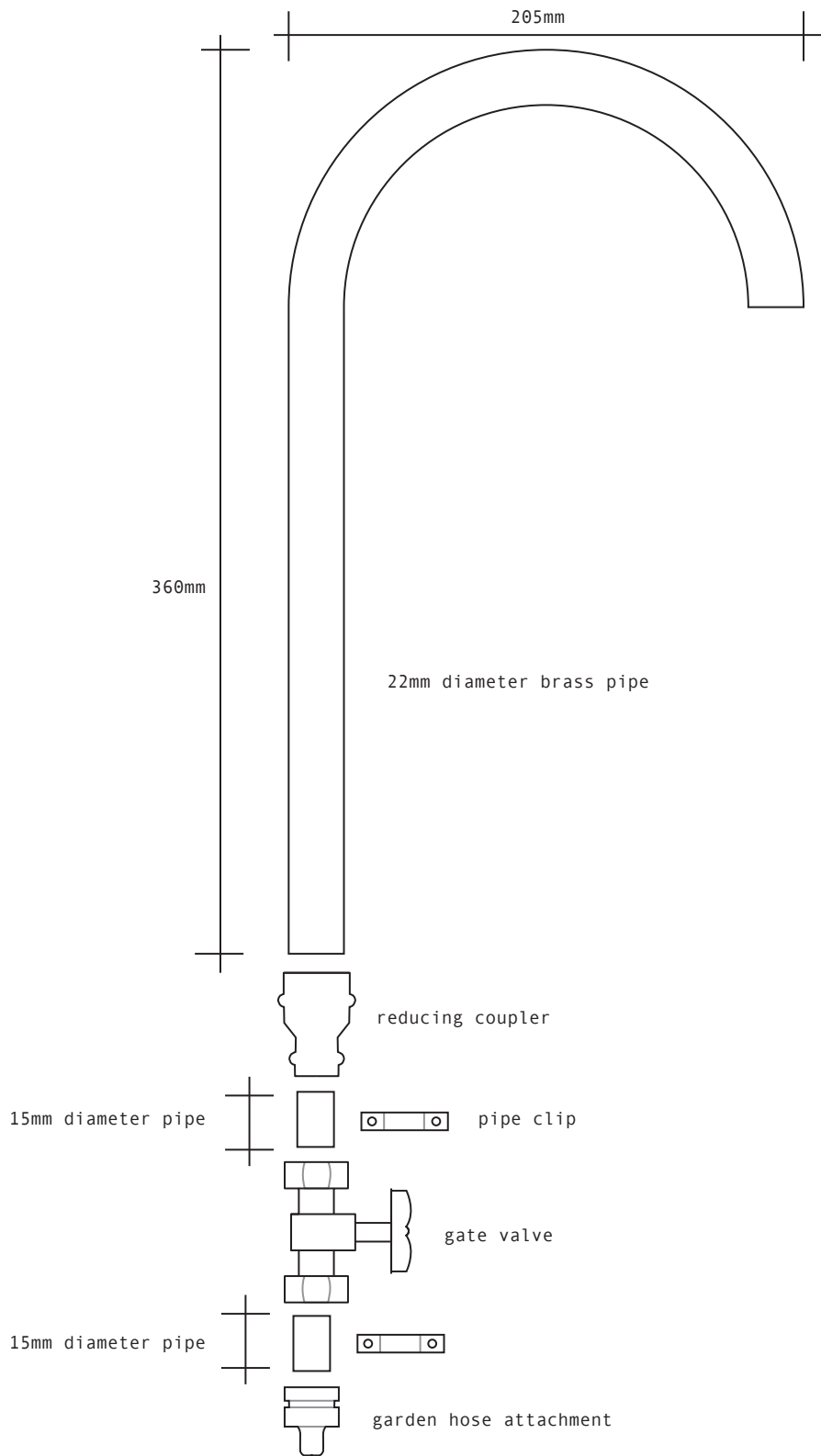

castor (metal rim heavy duty) 125mm 2 number

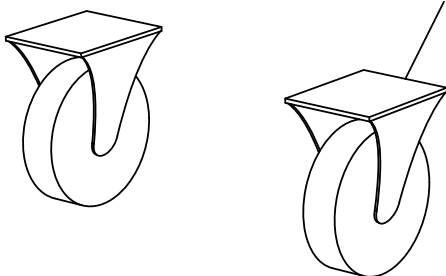

// BOX ASSEMBLY INSTRUCTIONS //

05 the first stage in making up the boxes is to construct them whilst not attached to the frame. this allows for a neat final construction. as the boxes are first made up, then disassembled before being threaded onto the frame it is important that some of the joints are not glued together. assemble each of the boxes as shown in the indicative sequence shown below. this is for the sink box.

05a lay the box out flat. for sides where there are double battens use selotape to separate the sides that will need to be glued later on in the sequence (indicatively shown in red)

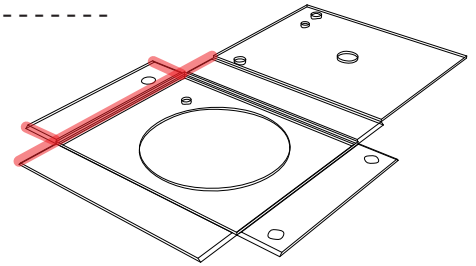

05b fold up the box gluing where required

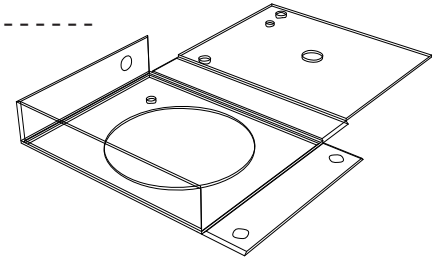

05c test that the bottom of the box fits tightly but do not connect. clamp together and wait till dry

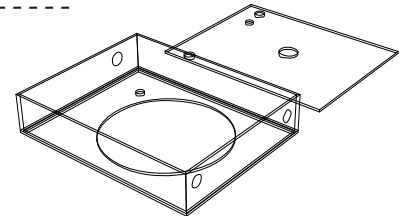

05d fit double battens to end remembering to selotape up where required

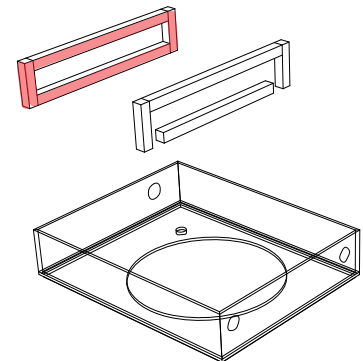

05e fit remaining battens

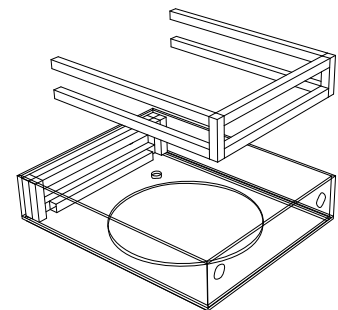

05f for double battens and fixing the bases of the boxes drill the holes in the battens which will later accept the screws.

05f test that the bottom of the box fits tightly but do not connect. clamp together and wait till dry

05g sand all pieces

05h Hoover all dust and debris from boxes

05i apply coating of finishing oil/paint as required

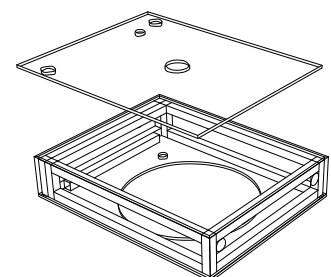

// BOX PART DESIGNATIONS //

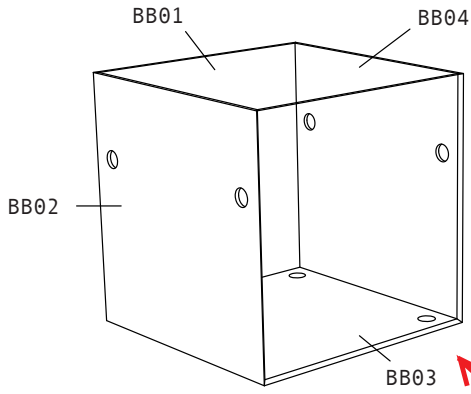

BB05 omitted for clarity

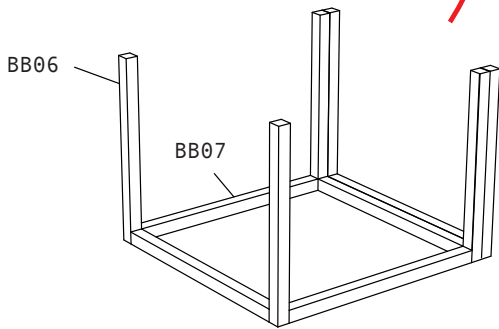

BURNER BOX

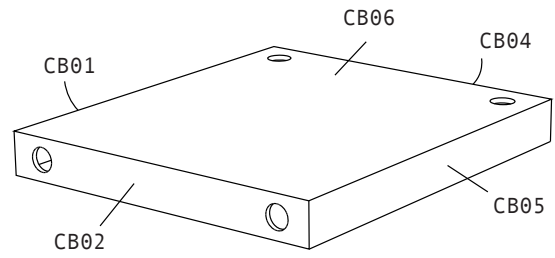
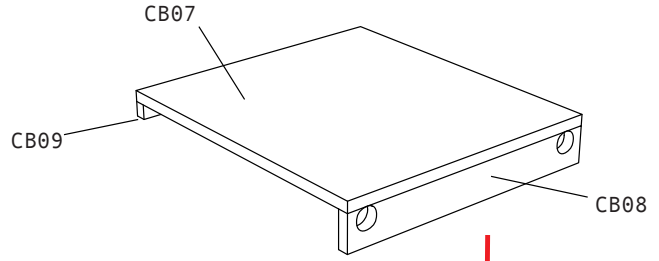

CHOPPING BOARD BOX

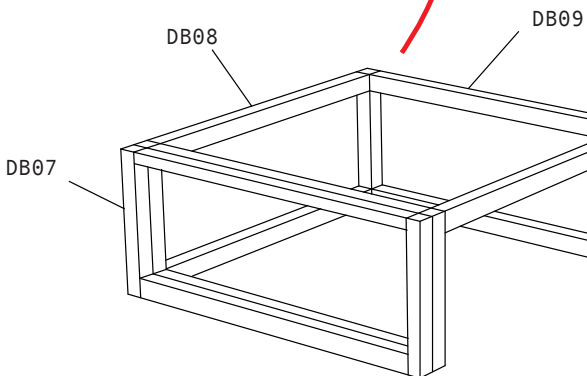
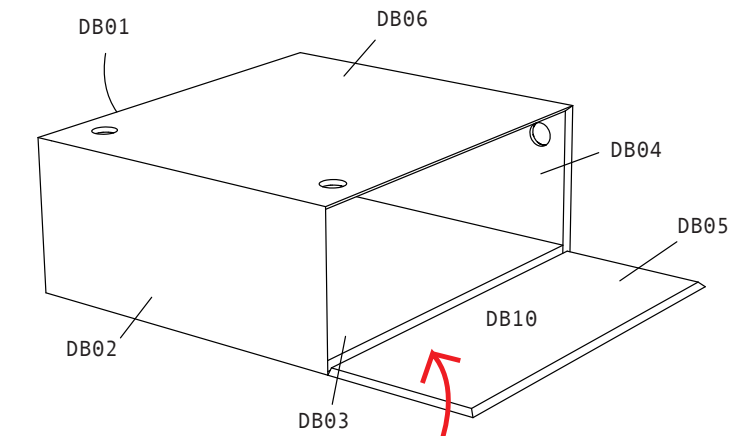

DRAWER BOX

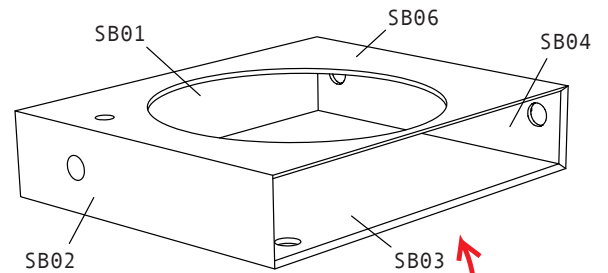

SB05 omitted for clarity

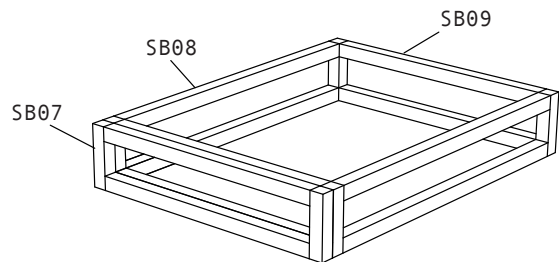

SINK BOX

07 making the connections in the frame requires a number of steps. please look at page "frame cutting list" which shows the setting out of the connections in the frame.

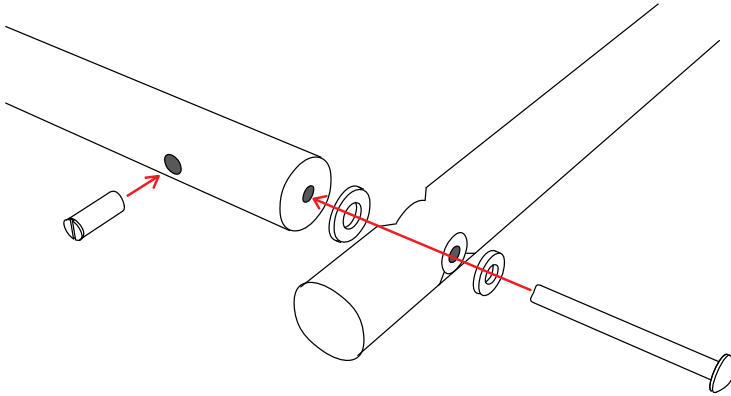

07a isometric showing how all the pieces fit together.

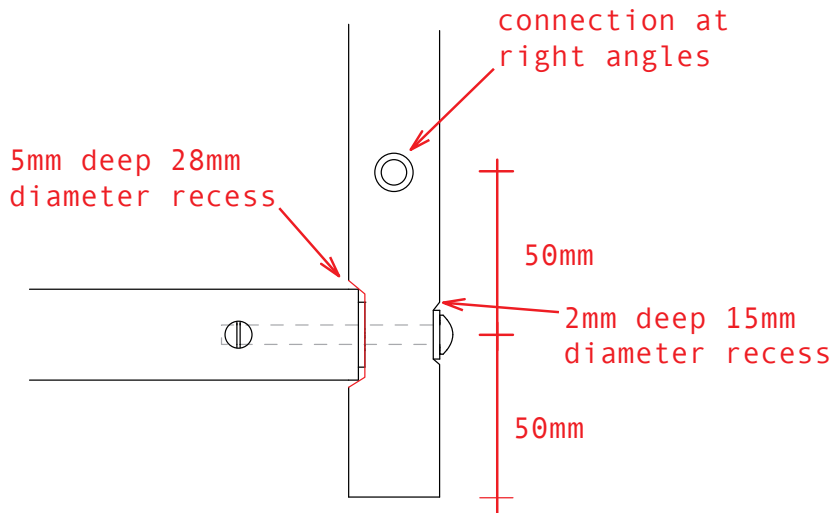

07b plan view showing two connections at right angles to one another.

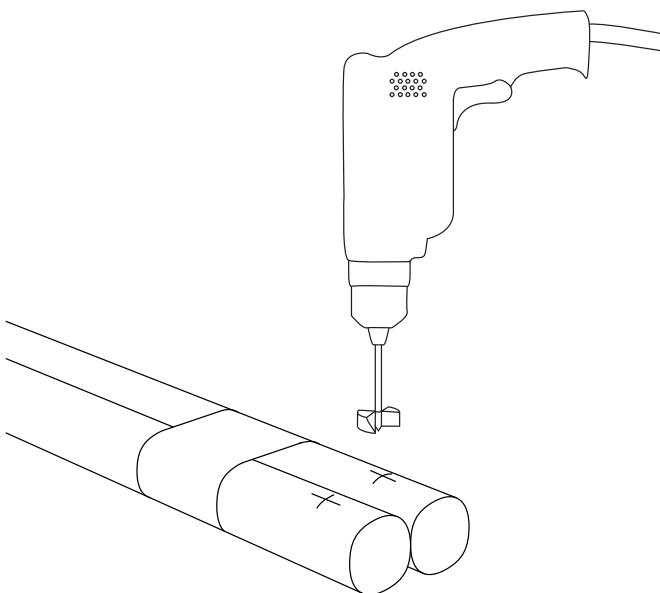

07c mark up where all connections are to be made on all broomsticks. remembering that the connections can on opposite sides of the broomsticks for both sides of the kitchen.

selotape two number broomsticks together to create an element which will not twist during drilling.

drill all large recesses 5mm deep.

07 drilling the holes for the cross dowels and their bolts

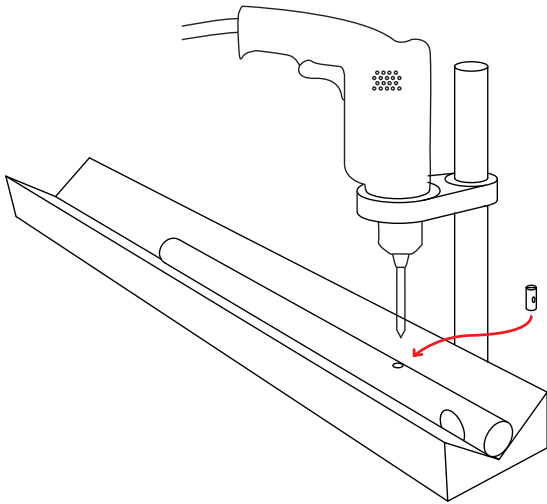

07j using a valley shaped rest to hold the broomstick in place drill the hole for the cross dowel at the correct location.

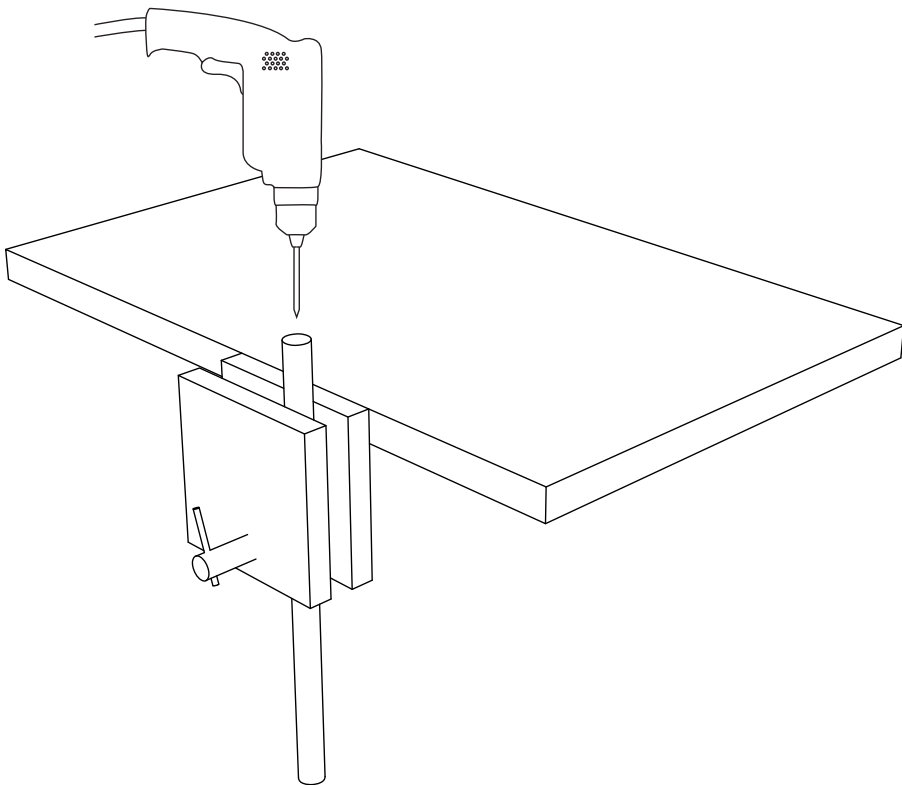

07k clamp the broomstick vertically in a table vice and drill the hole along the length of the broomstick to allow for insertion of the cross dowel bolt. as you will be drilling into the end grain of the broomstick start each hole with a centre punch. this will help reduce the likelihood of the drill being deflected from its path. great care should be taken whilst drilling into the end of the broomsticks as they or the drill are liable to move or slip during this process.

08 - 10 assembling boxes around frame

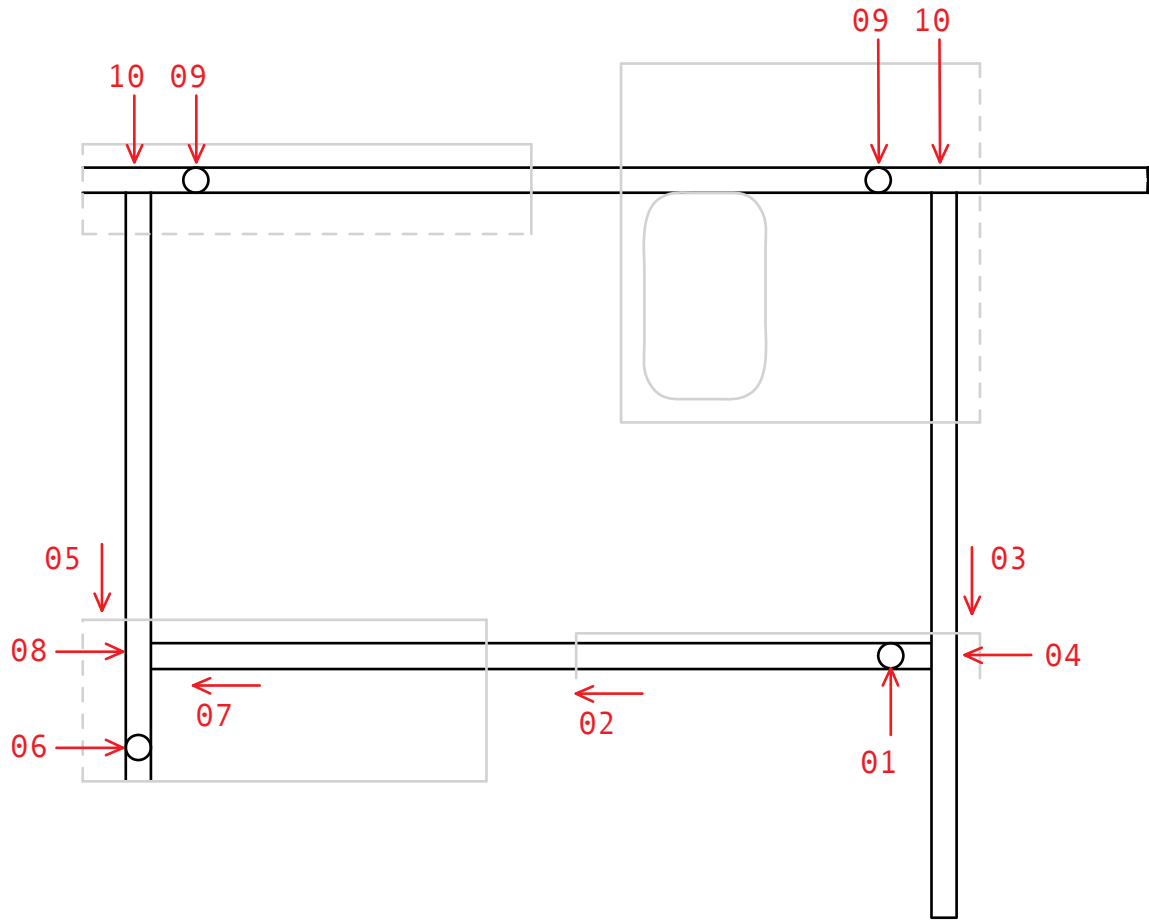

- broom handles
- - - outline of boxes
- - - - box sides to be fixed later

- 01 connect cross broom m whilst brooms are outside box
- 02 slide broom construction into box
- 03 slide brooms h and g into box
- 04 flex chopping board box up to access connection
- 05 slide brooms e and f into box
- 06 connection cross broom l see graphic below
- 07 slide frame construction into box
- 08 make connection
- 09 slide brooms a and b through both burner and sink boxes,
shuffle boxes along brooms to access connections
- 10 shuffle boxes along brooms to access connections
- 11 using double battons fix sides of boxes remaining

08 - 10 assembling boxes around frame cont.

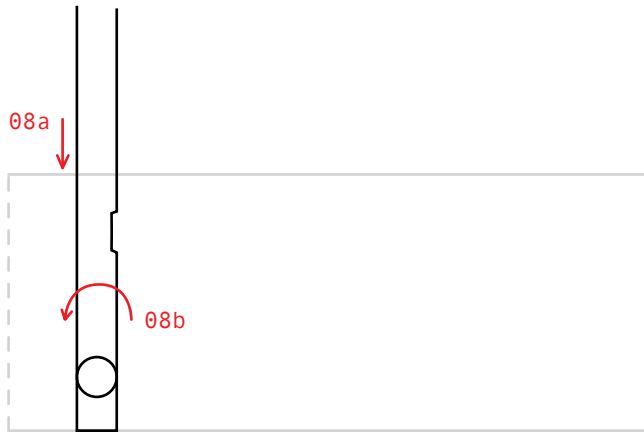

08a slide broom E into box

08b rotate so that
connection E-L faces
outwards

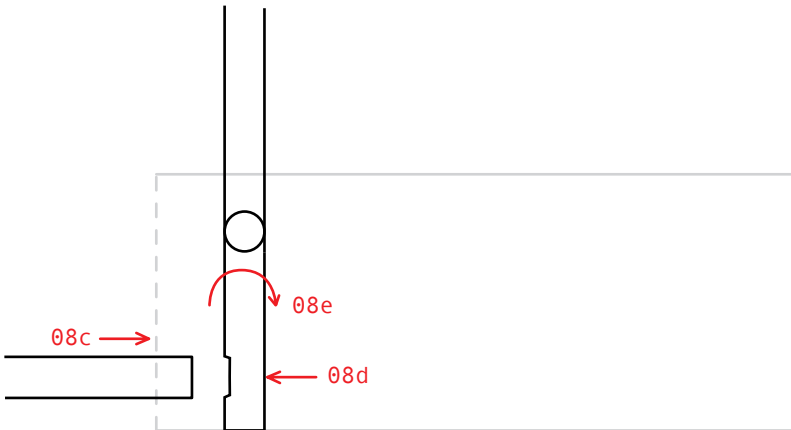

08c position broom L

08d connect brooms E and L

08e rotate through 90
degrees

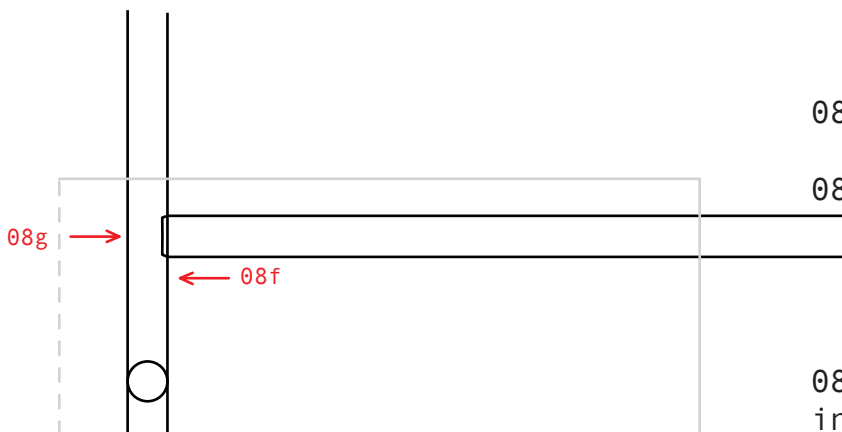

08f slide broom J into box

08g connection brooms E to J

08h slide brooms F and K
into box and connect

11 fixing the drawer door

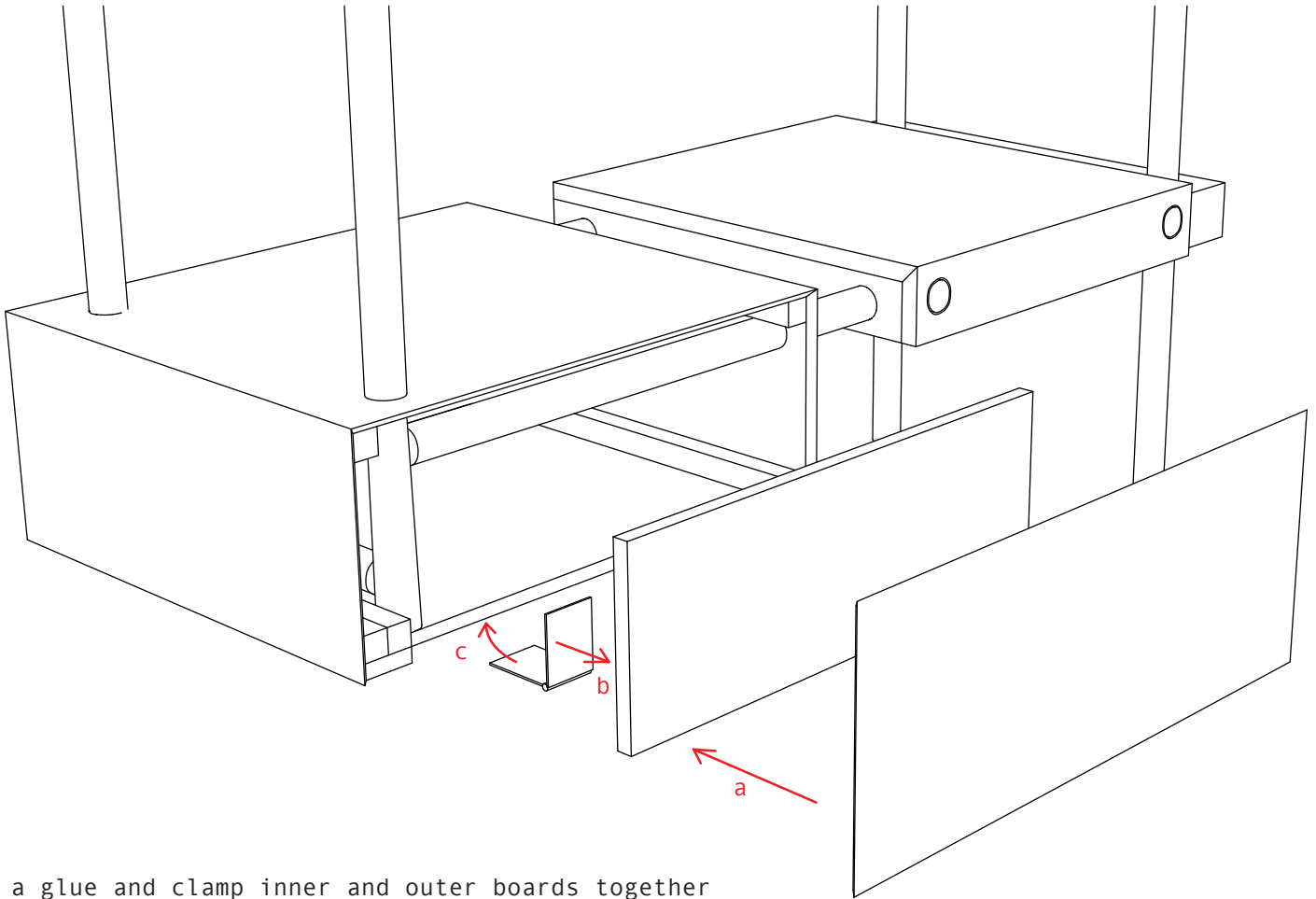

- a glue and clamp inner and outer boards together
- b screw hinge in upright side of inner board
- c screw hinge to underside of base of box

12 plumbing

using a pipe bender carefully bend the copper pipe to the required radius. be careful not to crimp the pipe whilst you are bending it.

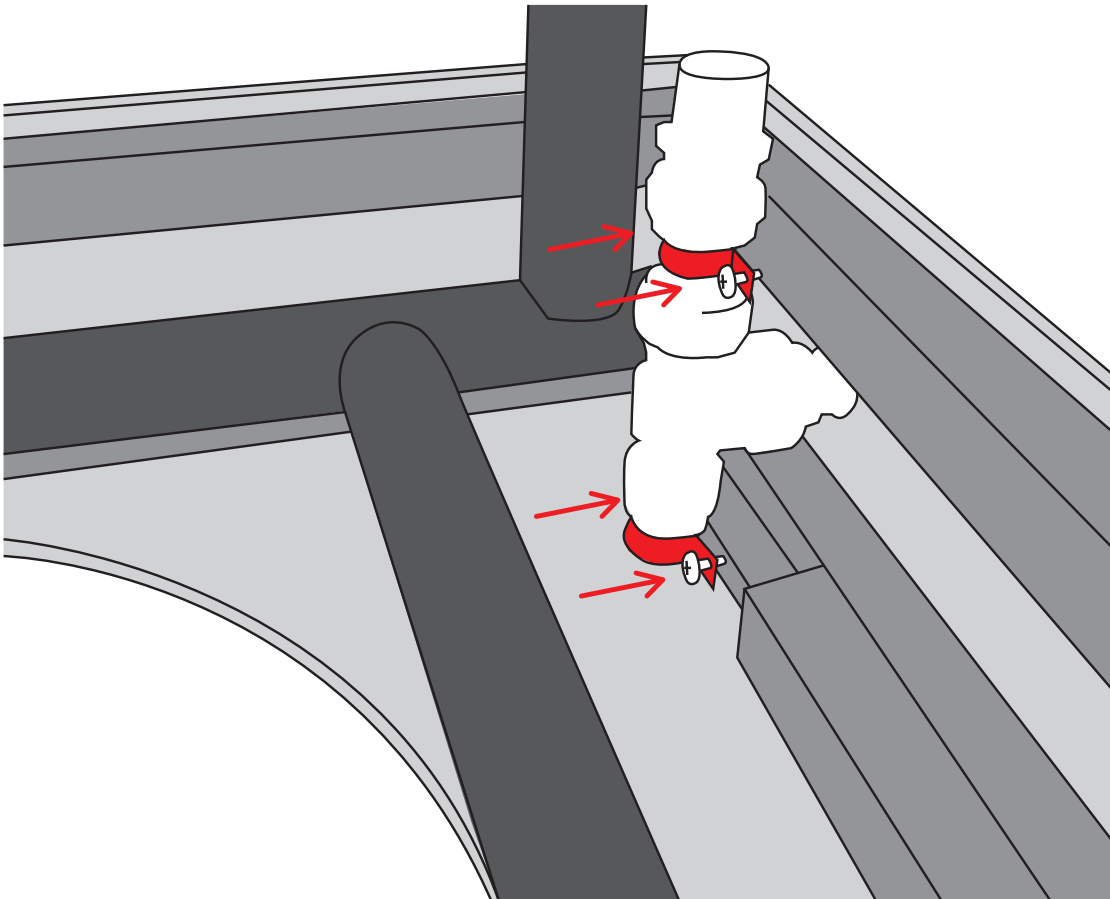
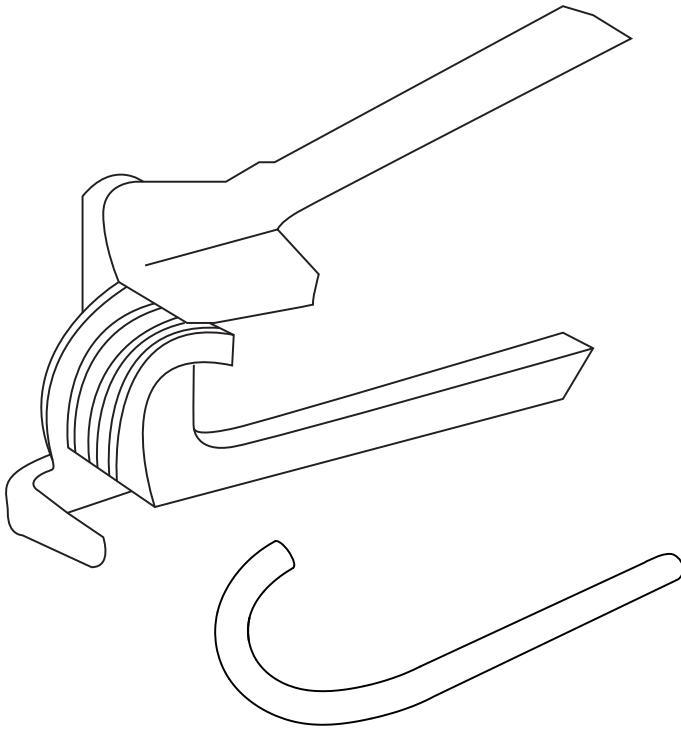

using pipe clips fix the plumbing to the battens with two number screws

13 making the chopping board.

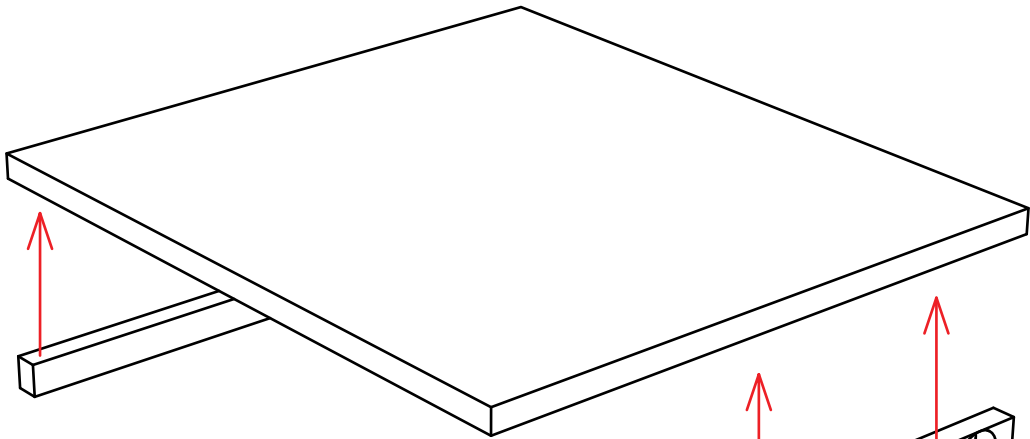

screw lower element to top of chopping board using 3 number 25mm long M4 screws

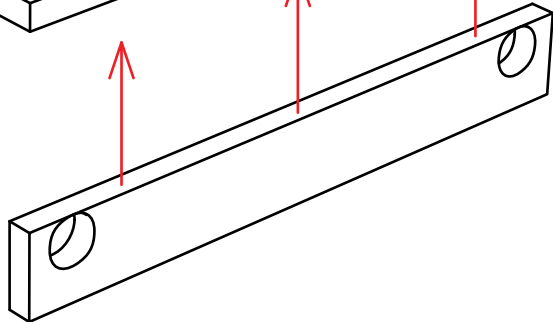

screw lower element to top of chopping board using 4 number 55mm long M6 screws

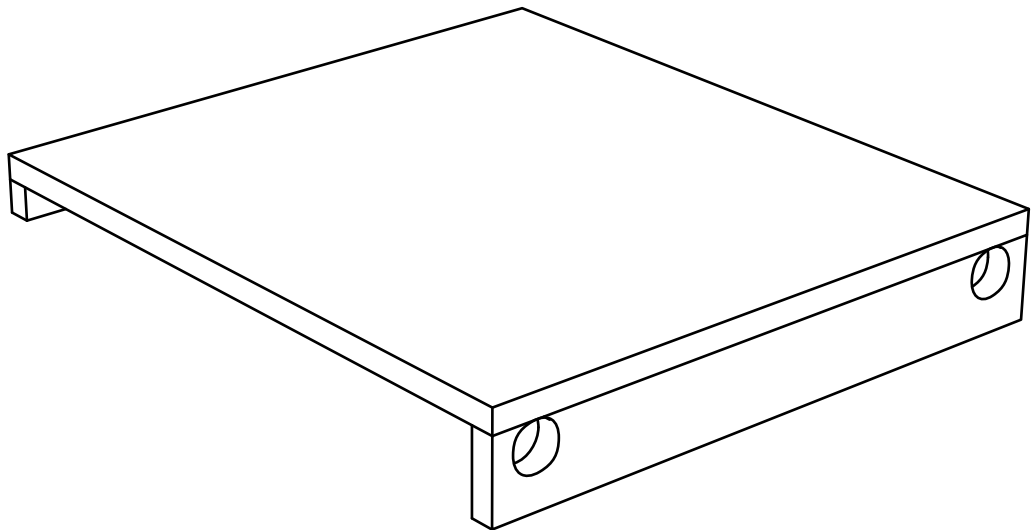

14 attaching the wheels

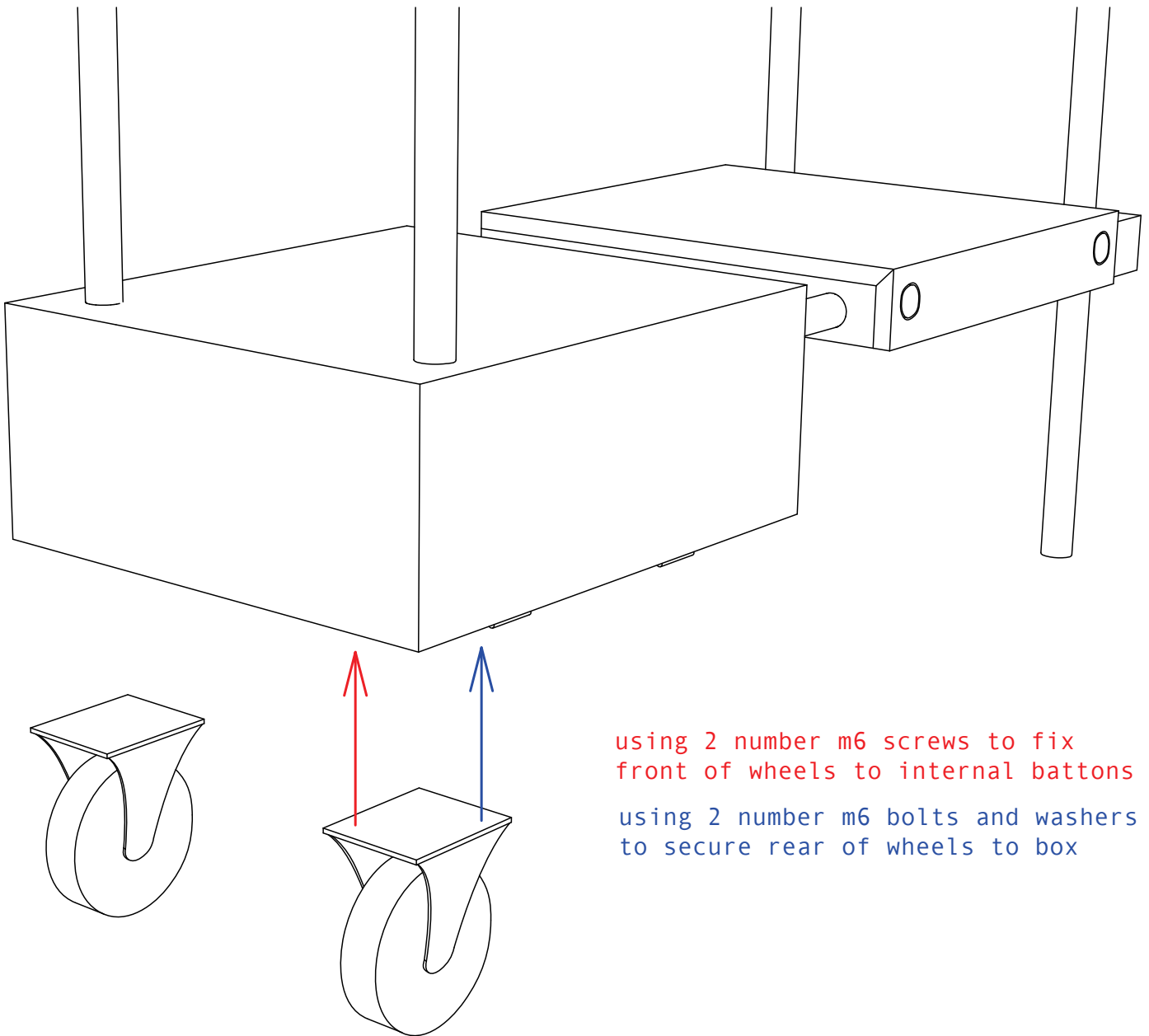

Your safety is your own responsibility, including proper use of equipment/safety gear and determining whether you have adequate skill/ experience. Power tools, electricity and other resources used for this projects are dangerous unless used properly and with adequate precautions, including safety gear. Some illustrations do not depict safety precautions or equipment, in order to show the project steps more clearly.

Use of the instructions and suggestions in TEN PLANS is at your own risk. Studiomama disclaims all responsibility for any resulting damage, injury, or expense. It is your responsibility to make sure that your activities comply with applicable laws, including copyright.